



TESTO INDUSTRY CORPORATION

177, Ind. 11 th Rd. Ta Li Ind. Zone
Ta Li City, Taichung, Taiwan
Tel: 886-4-2491-6801 Fax: 886-4-2491-6802

CHANGE NOTICE

ECN#:R991221-1

To Whom It May Concern:
January 6, 2011

Dear Sir,

Re.: CN45R5, CN2565S, CN2565S1

In order to prevent roll pin o-ring of feed piston dropping easily, we change the Shore A from A80~85 to A83~87. Please see below information for further understanding.

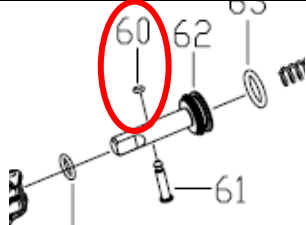
Part	Coil Nailer	
Drawing		
	Original	New
	<p>Parts number: 30700157000 US\$ 0.06 Shore A: A80~85 Color: Black</p>	<p>Parts number: 30700243000 US\$- Shore A: A83~87 Color: White</p>
Design Change	Change shore A and color	
Interchangeable	<ol style="list-style-type: none"> Part is interchangeable. Use new parts from now on. 	

Please feel free to let us know if there is any problem. We will do our best to serve your needs.

Best Regards,
Testo Industry Corp.
Michelle Tseng
C.C.: Annie Chiang